

### Tolerance

coasting	Fabricaton
Foam puya	ISO 2768(c)

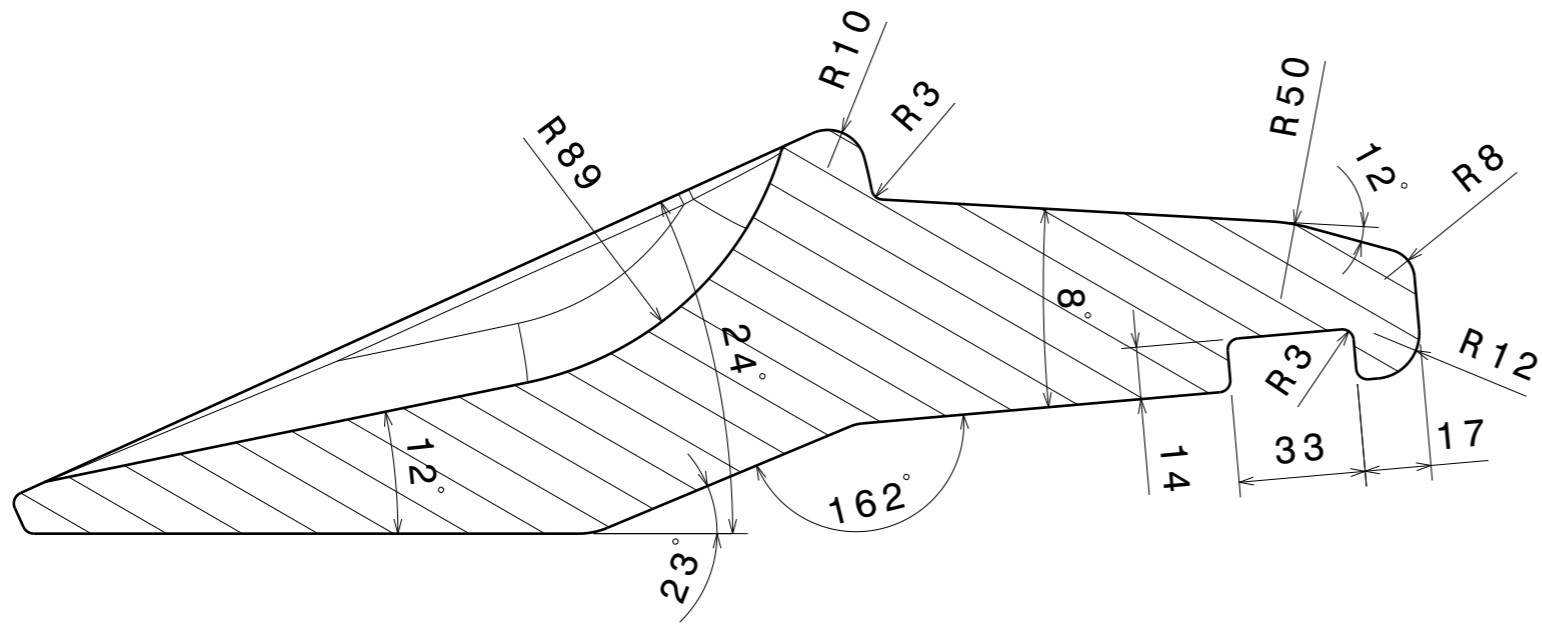

Section A-A

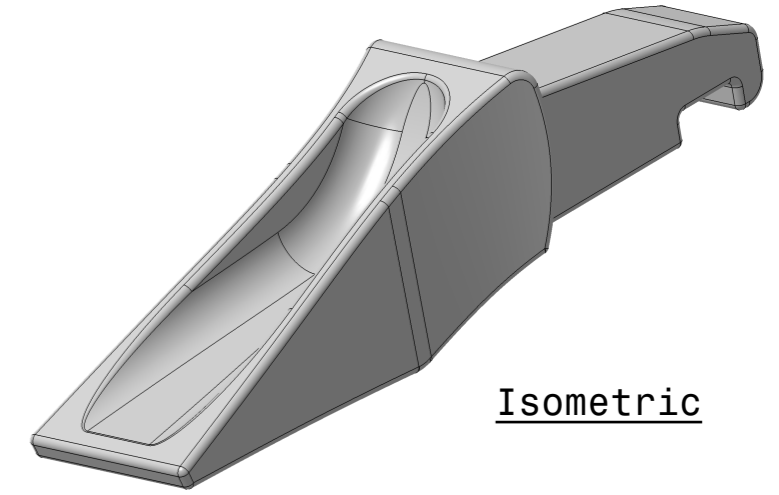
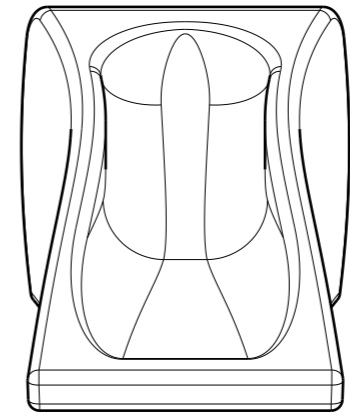

Isometric

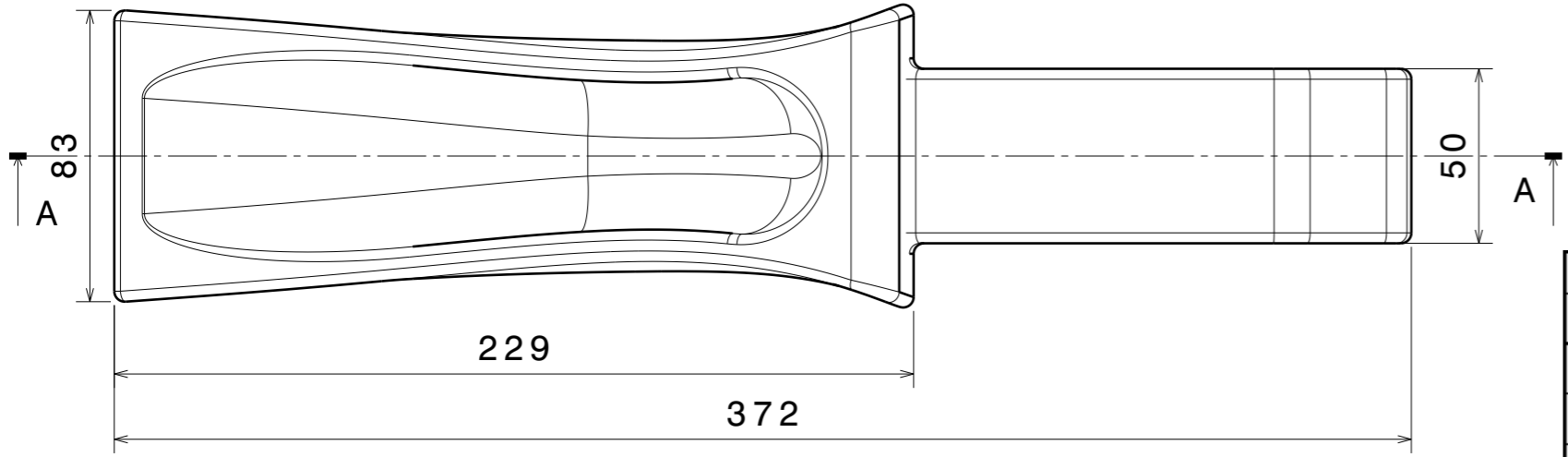

Surface Qualities (DIN 4766 T2)										
Zarrin kupal Puya No.	10	⑨	8	7	6	5	4	3	2	1
Micron Ra	25	12.5	6.3	3.2	1.6	0.8	0.4	0.2	0.1	0.05
Machining Symbols	—	~	∇	∇	∇∇					

		<b>POOLAD FOAM PUYA Co.</b>				
Project : Fork		Sheet 1 of 1 All Dimensions are in mm				
<b>Prototype</b> E.Froozan <b>Drawn</b> M.Absalan <b>Check</b> K.Salekfard <b>Appr.</b> H.Sorkhabi	<b>Title:</b>		<b>Rev.</b> 			
<b>Scale:</b> N.T.S	<b>Material:</b> See part list	<b>Weight Kg:</b> See part list	<b>Drawing No:(A3)</b>		<b>Rev.</b> 	

4

3

2

1

This drawing is our property. It can't be reproduced or communicated without our written agreement.