

H G F E D C B A

Tolerance

coasting	Fabricaton
Foam puya	ISO 2768(c)

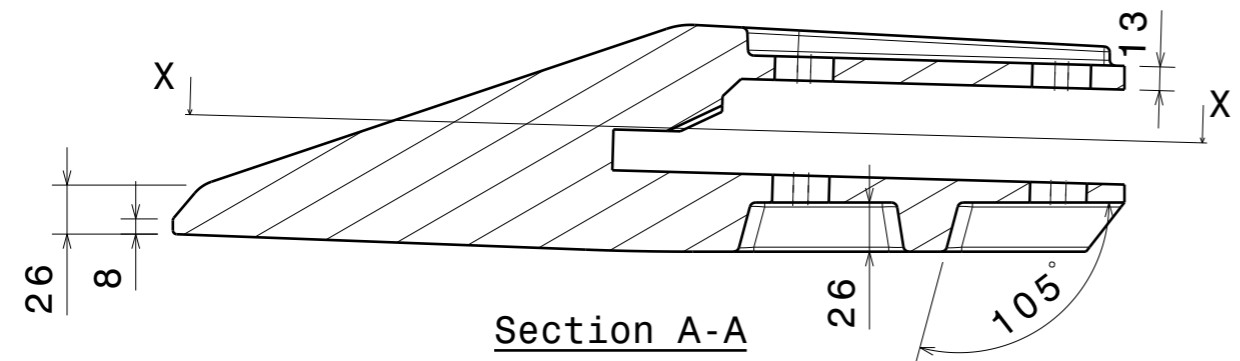

Section A-A

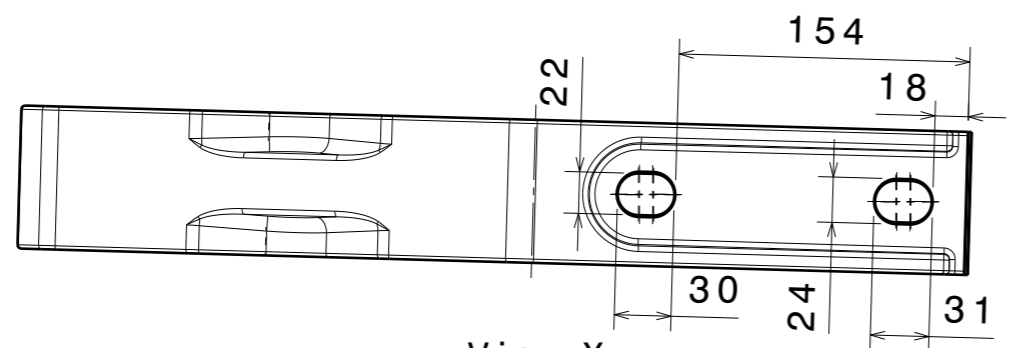

View X

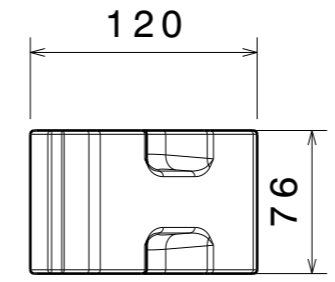
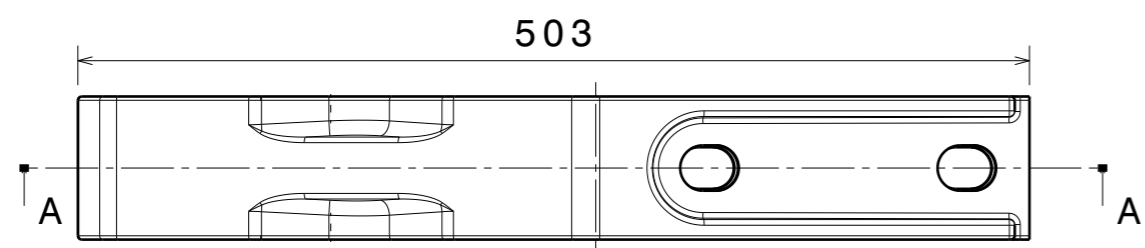

Isometric

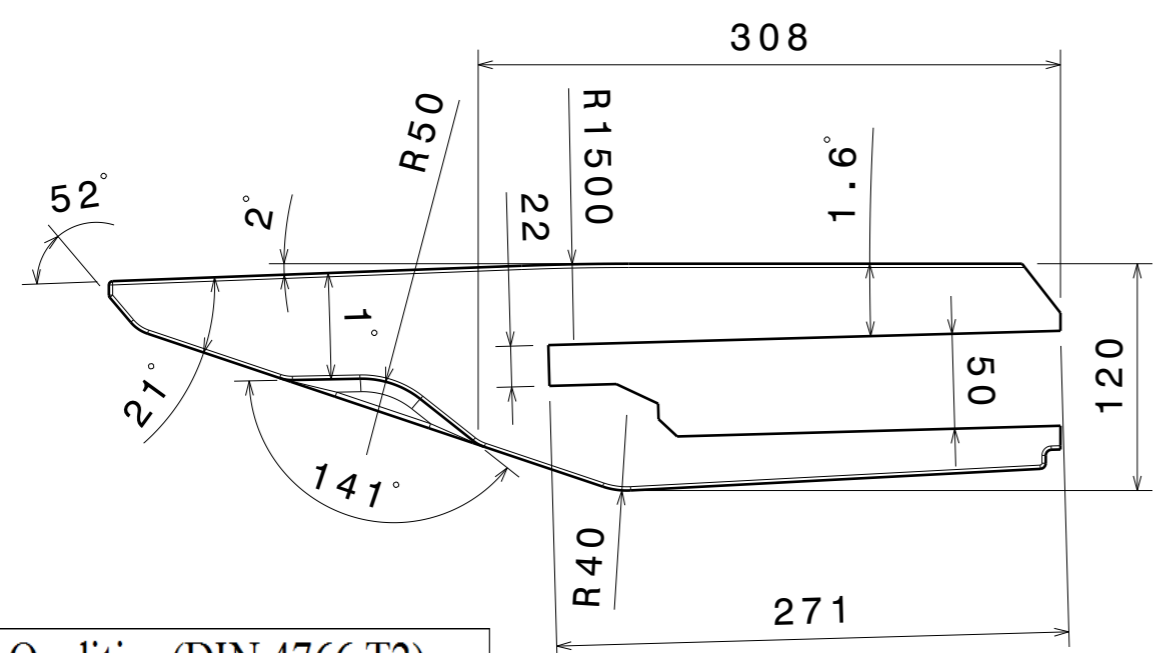
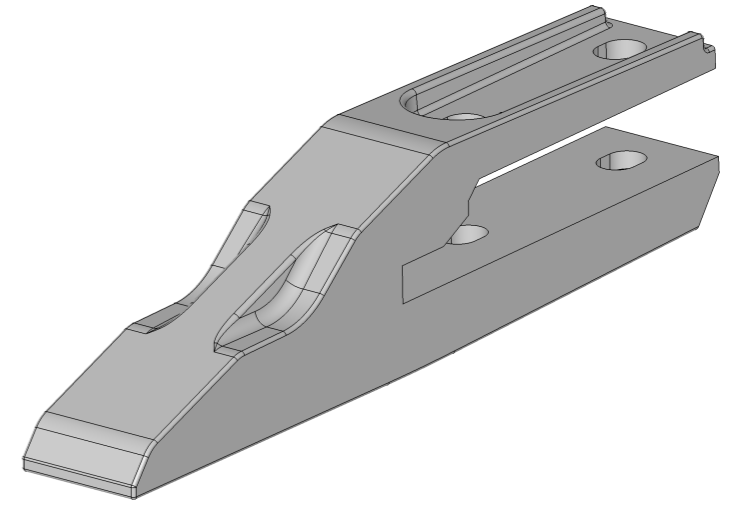

Surface Qualities (DIN 4766 T2)										
Zarrin kupal Puya No.	10	⑨	8	7	6	5	4	3	2	1
Micron Ra	25	12.5	6.3	3.2	1.6	0.8	0.4	0.2	0.1	0.05
Machining Symbols	—	~	∇	∇∇	∇∇∇					

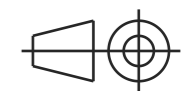
◆ General Revision		95.5.25	M.Absalan	E.Froozan	
Rev.	Modification	Date	Drawn	Checked	Appr.
				 Sheet 1 of 1 All Dimensions are in mm	
Project : Fork					
Prototype	E.Froozan			Title:	
Drawn	M.Absalan				
Check	K.Salekfard				
Appr.	H.Sorkhabi				
Scale:	Material:	Weight Kg:	Drawing No:(A3)		Rev.
N.T.S	See part list	See part list			◆

4

3

2

1

H G F E D C B A

This drawing is our property. It can't be reproduced or communicated without our written agreement.