

Performance curve

Pump name

3LP 32-200/4.0

Customer	Date	2021-04-20	Company
Contact	Item no.		Issued by
Phone	Project		Phone
E-mail	Project ID		E-mail

Requested data

1	Flow	m ³ /h
2	Head	m
3	Geodetic head	m

Pump

Operating Flow	m ³ /h	Frequency	Hz	50		
Operating Head	m	Number of poles	2			
Impeller Diameter	Designed	mm	200	Speed	rpm	2900

Test standard: ISO 9906:2012 - Grade3B

Water; 20°C; 998.3kg/m³; 1cSt

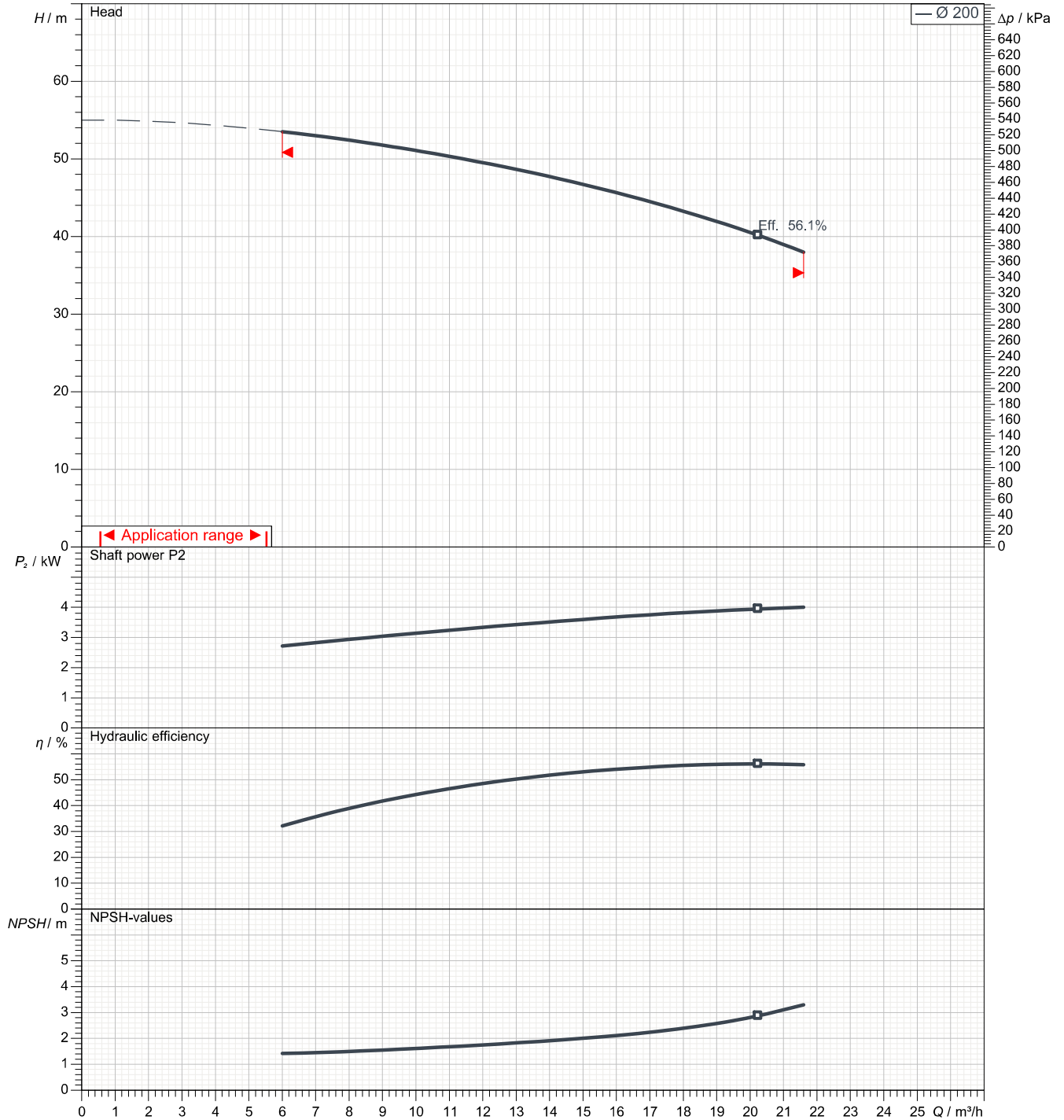

Dimensions

Pump name 3LP 32-200/4.0

Customer	Date 2021-04-20	Company
Contact	Item no.	Issued by
Phone	Project	Phone
E-mail	Project ID	E-mail

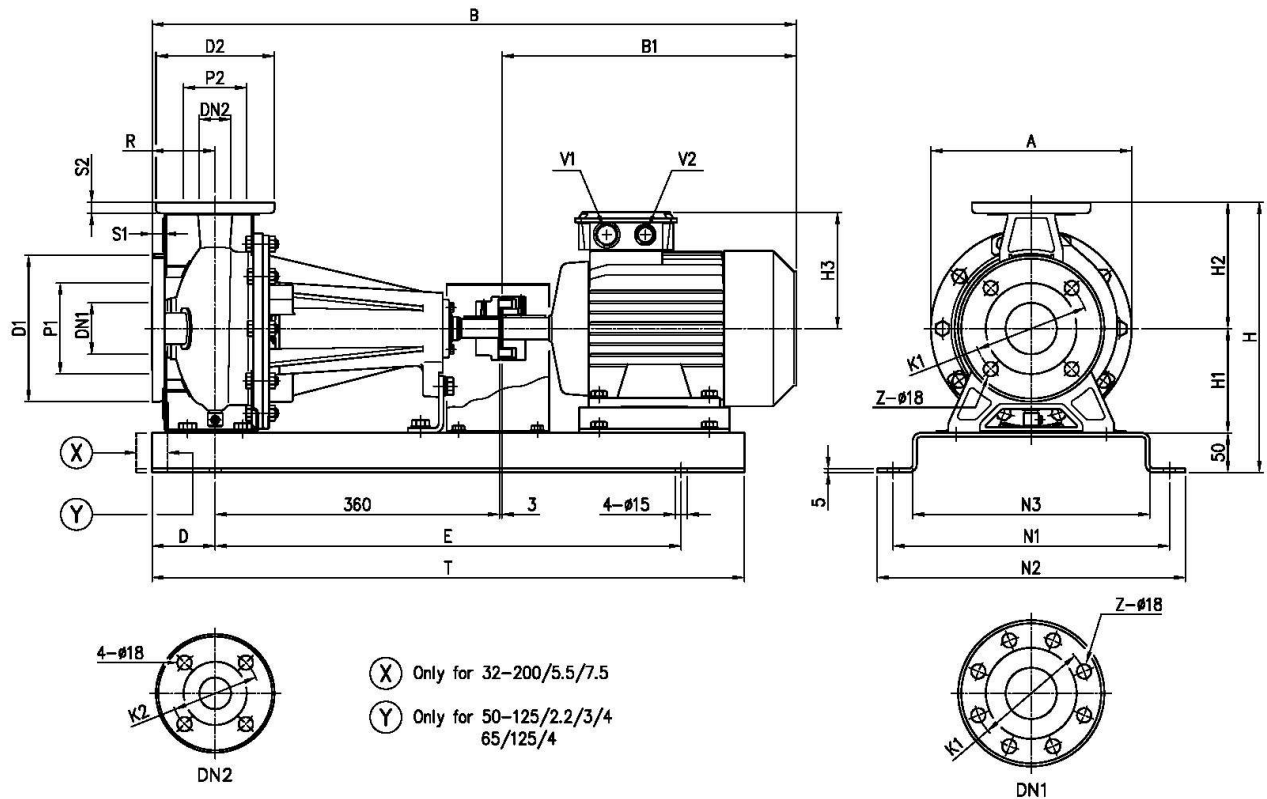

Dimensions in		mm						
1	A	296	H2	180				
2	B	831	H3	171				
3	B1	388	N1	350				
4	D	80	N2	390				
5	Dia D1	165	N3	300				
6	Dia D2	140	R	80				
7	Dia DN1	50	S1	16				
8	Dia DN2	32	S2	14				
9	Dia K1	125	T	750				
10	Dia K2	100	V1	M25x1,5				
11	Dia P1	95	V2	M20x1,5				
12	Dia P2	75	Weight P&M	75,1 kg				
13	E	590	Z	4				
14	H	390						
15	H1	160						